



National Headquarters:
514 Progress Drive, Suite A
Linthicum Heights, MD 21090
845-878-4200
nfsa.org

NATIONAL FIRE SPRINKLER ASSOCIATION

INSULATION FOR FIRE SPRINKLERS GUIDE

April 2020

CONTENTS

1.0 Introduction

2.0 Contributors

3.0 Definitions

4.0 NFPA Standards

NFPA 13-2019

NFPA 13R-2019

NFPA 13D-2019

5.0 Design Considerations

6.0 Installation Considerations

7.0 Conclusion

Annex A

References

1.0 Introduction

Fire sprinkler systems have proven to be effective in providing protection of lives and property when properly designed, installed, and maintained. Areas where temperatures reach or drop below freezing at any point throughout the year require sprinkler systems to be protected against freezing. The industry accepted practice is to provide protection for water-filled piping in sprinkler systems when they are subject to freezing and exposed to temperatures below 40 °F (4°C) as required in NFPA sprinkler installation standards.

Pipe insulated from an unconditioned space is one of many acceptable methods for providing freeze protection; however, this is only accomplished by using adequate insulating materials with thermal properties consistent with nationally recognized model building and energy codes and the climate region in which they are installed.

The scope and responsibility for the installation of insulation varies from job to job and contract to contract. This brief document is intended to identify considerations for those responsible for designing and installing insulation as a means of protecting sprinkler systems against freezing.¹

¹ Responsible parties could include, but are not limited to, one of or a combination of the following: the general contractor, the insulation contractor, or the home/building owner. In most cases, insulation will be excluded from the scope of work for sprinkler contractors.

2.0 Contributors

NFSA would like to thank the following individuals for their collaboration in developing this document. The individuals are listed below with their areas of expertise noted²:

Fred Benn, Advanced Automatic Sprinkler, Inc. (I-CA)

Timothy Bowe, ABCO Peerless Sprinkler Corp. (I-NY)

Frank Bridges, Knauf Insulation (M)

Daniel Buuck, National Association of Home Builders (TA)

Charles Cottrell, North American Insulation Manufacturers Association (TA)

Rick Duncan, Spray Polyurethane Foam Alliance (TA)

Scott Enides, SRI Sprinkler (I-NY)

Mark Fessenden, Johnson Controls, Inc. (M)

Charlie Haack, North American Insulation Manufacturers Association (TA)

Kevin Hall, National Fire Sprinkler Association (TA)

Mark Hopkins, National Fire Sprinkler Association (TA)

Jonathan Humble, American Iron and Steel Institute (TA)

Bill Ivans, Verisk (R)

Top Meyers, Meyers Risk (R)

William Roberts, Quick Response Fire Protection (I-NJ)

Pete Schwab, Wayne Automatic Fire Sprinkler, Inc. (I-FL)

Manny Silva, Johnson Controls, Inc. (M)

Don Townley, Lubrizol (M)

² I-XX – Installer (State); M – Manufacturer; R – Risk Management/Insurance; TA – Trade Association.

3.0 Definitions

Definitions are used within the context of this paper based on generally accepted meanings. Italicized definitions have been accepted by a consensus standard cited in section 7 of this document.

Building envelope³ All of the elements of the outer shell that maintain a dry, heated, or cooled indoor environment and facilitate its climate control [1]

Conditioned space *Cooled space, heated space, or indirectly conditioned space.* [2]

Indirectly Conditioned Space *Enclosed space within a building that is not a heated space or a cooled space, which is heated or cooled indirectly by one of the following methods*

(1) being connected to adjacent space(s) provided the product of the U-factor(s) and surface area(s) of the space adjacent to connected space(s) exceeds the combined sum of the product of the U-factor(s) and surface area(s) of the space adjoining the outdoors, unconditioned spaces, and to or from semi-heated spaces (e.g., corridors)

(2) air from heated or cooled spaces is intentionally transferred (naturally or mechanically) into the space at a rate exceeding 3 air changes per hour (ACH) (e.g., atria). [2]

Insulated pipe Pipe utilizing insulation as a means of freeze protection. It can be the sole means of protection or used in conjunction with another approved freeze protection method.

Pipe insulated from an unconditioned space Pipe installed adjacent to a *conditioned space* (above, below, or to the side) where insulation is installed as a thermal barrier between the pipe and the *unconditioned space*. Proper installation of this thermal barrier creates an *indirectly conditioned space* where the pipe is installed.

Pipe wrapped in insulation⁴ Pipe installed in an *unconditioned space* with insulation fully surrounding the pipe.

Subject to freezing Pipe installed in an *unconditioned space* where expected temperatures would allow the freezing of water-filled pipe.⁵

Thermal envelope⁶ Part of a building envelope but maybe in a different location such as in a ceiling. The difference can be illustrated by understanding that an insulated attic floor is the primary thermal control layer between the inside of the house and the exterior while

³ This element is typically outside the sprinkler contractor's scope of work and a responsibility of another party.

⁴ Severe limitations on the use of this practice as applied to sprinkler system piping are discussed later in this paper.

⁵ See section 4 for design considerations for temperature below 40°F and no other mean of freeze protection installed.

⁶ This element is typically outside the sprinkler contractor's scope of work and a responsibility of another party.

the entire roof (from the surface of the roofing material to the interior paint finish on the ceiling) comprises the building envelope. [3]

Unconditioned space *Enclosed space within a building that is not a conditioned space or a semi-heated space. Crawlspace, attics, and parking garages with natural or mechanical ventilation are not considered enclosed spaces. [2]*

4.0 NFPA Standards

Freeze protection requirements are concisely identified in each of the three sprinkler installation standards. Requirements permitting the use of insulation without heat loss calculations are summarized in the extractions below.

NFPA 13 Standard for the Installation of Sprinkler Systems, 2019 Edition (NFPA 13-2019) [4]:

16.4.1.1* *Where any portion of a system is subject to freezing and the temperatures cannot be reliably maintained at or above 40° F (4° C), the system shall be installed as a dry pipe or preaction system.*

A.16.4.1.1 *Water-filled piping can be run in spaces above heated room, such as attics, even if the space above the room is not heated itself. Insulation can be located above the pipe to trap the heat from below and prevent the pipe from freezing. It is important not to bury the piping in the insulation because if too much insulation ends up between the pipe and the heated space, the insulation will prevent the heat from getting to the pipe. This method of protecting the pipe is acceptable to this standard.*

16.4.1.3 *Where aboveground water-filled supply pipes, risers, system risers, or feed mains pass through open areas, cold rooms, passageways, or other areas exposed to temperatures below 40° F (4° C), the pipe shall be permitted to be protected against freezing by insulating coverings, frostproof casings, or other means of maintaining a minimum temperature between 40° F (4° C) and 120° F (49° C).*

The annex note to NFPA 13-2019 Section 16.4.1.1 explains that insulation uses heat from a *conditioned space* around water-filled sprinkler pipes is acceptable where the application is also insulating the pipe from an *unconditioned space*. While annex notes in NFPA Standards are unenforceable and explanatory in nature, the use of insulation in the manner described in Section A.16.4.1.1 would create an *indirectly conditioned space* per ASHRE 90.1-2019 and the water-filled pipe would not be *subject to freezing*.

It should be noted that Section 16.4.1.3 is a special case where insulation can be provided in an *unconditioned space* to protect large diameter pipes from freezing. The section specifically calls out supply pipes, risers, system risers, or feed mains as the applicable sprinkler system components to this requirement. The types of pipes listed in Section 16.4.1.3 are typically large in diameter and therefore have a thermal mass substantial enough to limit the potential of freezing. This is the only instance where sprinkler pipe should be wrapped. The key to this requirement is that the heat loss of the water-filled pipe to the *unconditioned space* will be less than heat gained by either side of the pipe coming from adjacent conditioned spaces.

NFPA 13R Standard for the Installation of Sprinkler Systems in Low-Rise Residential Occupancies, 2019 Edition (NFPA 13R-2019) [5]:

5.4.2* Systems in Areas Subject to Freezing. Where any portion of a system is subject to freezing and temperature cannot be maintained reliably at or above 40°F (4°C), the pipe shall be protected by use of one of the following methods:

- (1)*Antifreeze system using a listed antifreeze solution in accordance with NFPA 13
- (2) Dry pipe system
- (3) Preaction system
- (4) Listed dry pendent, dry upright, or dry sidewall sprinklers extended from pipe in heated areas
- (5) Heat tracing in accordance with 6.7.2.2

A.5.4.2 Piping covered by insulation, as shown in Figure A.5.4.2(a) through Figure A.5.4.2(f), is considered part of the area below the ceiling and not part of the unheated attic area.

The pointers to insulation in NFPA 13R-2019 follow the same structure as NFPA 13-2019 as they are located in the annex. NFPA 13R-2019, however, provides additional support that *pipe insulated from an unconditioned space* is permitted. This creates an *indirectly conditioned space* and therefore does not require additional calculations as long as the insulation is sufficient as it relates to locally adopted building and energy codes.

NFPA 13D Standard for the Installation of Sprinkler Systems in One- and Two-Family Dwellings and Manufactured Homes, 2019 Edition (NFPA 13D-2019) [6]:

9.1.1* Wet Pipe Systems. A wet pipe system shall be permitted to be used in areas not subject to freezing, including areas properly insulated to maintain 40°F (4°C).

A.9.1.1 In areas subject to freezing, care should be taken in unheated attic spaces to cover sprinkler piping completely with insulation. Installation should follow the guidelines of the insulation manufacturer. Figure A.9.1.1(a) through A.9.1.1(f) show several methods that can be considered. These are for illustrative purposes only. Consultation with the general contractor and/or owner is recommended to ensure proper methods and materials are used to make sure 40°F will be maintained.

The Fire Protection Research Foundation completed a research project (“Sprinkler Insulation: A Literature Review,” July 2011) on the use of insulation to protect sprinkler pipe from freezing that can be downloaded for free from their website.

NFPA 13D-2019, again, provides language similar to NFPA 13-2019 and NFPA 13R-2019. In a more detailed annex note, installation guidelines are discussed for the first time. Proper insulation thickness should be taken into account through the locally adopted building and energy codes, and

installation techniques should follow the manufacturer's installation instructions. While the attic itself is *subject to freezing* as referenced in A.9.1.1, the addition of insulation between the water-filled pipe and the *unconditioned space* will create the *indirectly conditioned space* as discussed in previous sections of this paper.

While protection from freezing is the main concern of the installation standards, NFPA 13D-2019 provides additional requirements regarding the overheating of pipe beyond its rated temperature:

7.7 Attics. *When nonmetallic piping is installed in attics, adequate insulation shall be provided on the attic side of the piping to avoid exposure of the piping to temperatures in excess of the pipe's rated temperature.*

Insulation works to protect water-filled pipe from extreme temperatures on both sides of the scale. When temperatures in an unconditioned space can exceed the rated temperature of pipe used in that space, the methods outlined in the installation standards can be an effective means to have the *pipe insulated from an unconditioned space* and maintain temperatures in an acceptable range.

5.0 Design Considerations

It has been occasionally suggested that calculations performed by a professional engineer are required to utilize insulation. NFPA 13-2019 has one section relating to that topic for temperatures below 40°F:

16.4.1.5 *Water-filled piping shall be permitted to be installed in areas where the temperature is less than 40°F (4°C) when heat loss calculations performed by a professional engineer verify that the system will not freeze.*

This requirement specifically relates to water-filled pipe installed with no other means of freeze protection in an area that the ambient temperatures fall below 40°F but the water-filled pipe is not *subject to freezing*. If an installation meets one of the other requirements of NFPA 13-2019 Section 16.4.1, then heat loss calculations are not required.

Building and energy codes provide requirements for insulation, including specifications of minimum R-Values, that are applied by project design professionals as part of the normal building regulatory process. Where insulation with sufficient R-Values per the building and energy code is installed and placed as a thermal barrier between water-filled pipe and an *unconditioned space*, an *indirectly conditioned space* is created which requires no supplemental calculations.

In an article published in *Sprinkler Quarterly* [7], it was shown that the amount of insulation calculated to properly protect water-filled pipe from freezing is less than the insulation requirements of modern energy and building codes. Similarly, the *pipe insulated from an unconditioned space* can be protected from excess temperatures when located in areas where elevated temperatures beyond which the materials are rated are possible when protected with insulation.

6.0 Installation Considerations

Where insulation is selected as discussed in the design considerations of this document, care should be taken to ensure the integrity of the *indirectly conditioned space*. The following list provides some installation aspects derived from observations in a literature review conducted by the National Fire Protection Research Foundation [8] to take into consideration to ensure proper protection from freezing:

- Acceptable insulation materials
 - Batt insulation (faced or unfaced)
 - Loose-fill cellulose
 - Rigid polyurethane foam
 - Spray applied polyurethane foam⁷
 - Other insulators with an appropriate R-Value
 - Compatibility with the fire protection system components shall be considered when selecting the insulation type
- General installation techniques
 - No insulation should be present between water-filled pipe and a conditioned space
 - Limit gaps between insulating materials
- Batt insulation installation techniques
 - Batts should be secured in place
 - Staple batts a minimum of every 6 in.
 - Where joist widths exceed 4 ft., extend insulation 2 ft on both sides of the water-filled pipe
 - Extend insulation 6 in. from the ends of the water-filled pipe
 - Where multiple layers of batt insulation are installed, it is most effective to cross-link batts to cover gaps
- Loose-fill cellulose installation techniques
 - Provide a barrier between the pipe and insulation to prevent filling the air gap in the *indirectly conditioned space*
 - Secure the barrier in the same manner as batt insulation
 - Account for a 20% reduction in thickness and R-value as the product settles over time
- Spray applied polyurethane foam
 - Verify material compatibility with nonmetallic pipe prior to application
 - Application process involves an exothermic reaction and temperatures in the application space need to be maintained below the rated temperature of the appurtenances of the sprinkler system or the system would need to be installed after application

⁷ This material is effective when applied to exterior surfaces of an *unconditioned space* such as an unventilated attic. When installed per the manufacturer's recommendations, the space would be considered a part of the thermal envelope of the building and a *conditioned space* not requiring any additional freeze protection.

7.0 Conclusion

All water-filled pipe must be installed inside the thermal envelope of a building unless it is otherwise protected by a means of listed antifreeze, listed heat-tracing system, or other means of freeze protection recognized by the NFPA sprinkler installation standards or proven to not be *subject to freezing* by a heat loss calculation. The use of insulation extends the thermal envelope of the building allowing the water-filled pipe to be installed without risk of freezing. If the thermal envelope of insulation is installed correctly and in accordance with locally adopted building and energy codes, water-filled piping in the *indirectly conditioned space* should be protected against freezing.

Annex A

This section provides examples of insulation installations that should be generally accepted without engineered heat loss calculations when insulation thicknesses (R-Values) meet or exceed the Building and Energy Code's requirements for the thermal envelope. These details are not meant to assign responsibility to any particular party, as the specific scope of work for each individual project should be determined by privity of contract and the terms agreed to by the parties therein. In addition, these details are not an all-inclusive list of all acceptable arrangements.

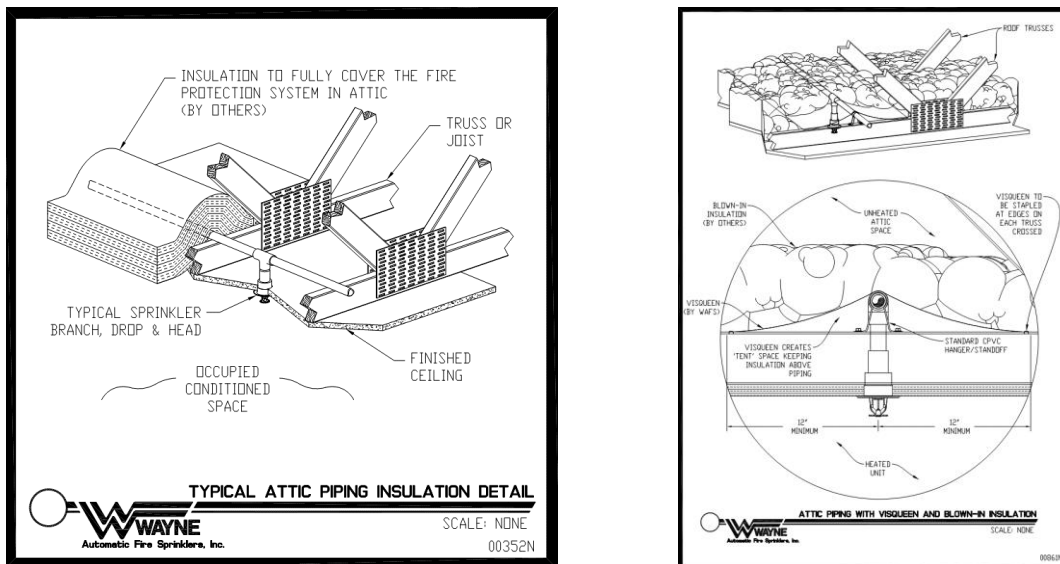
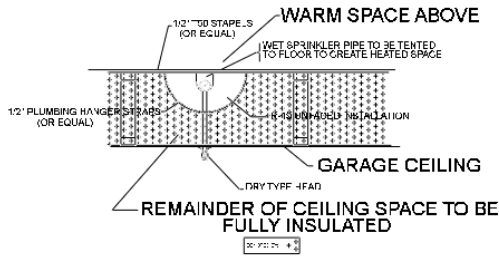
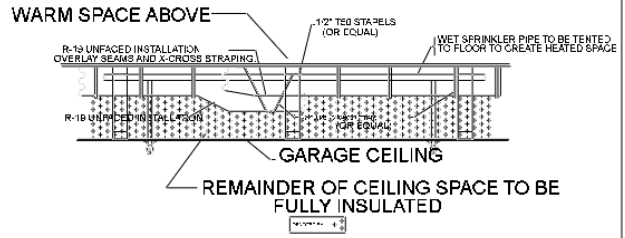

Figure A.1 – Sprinkler Pipe Installed in Attics (Above Conditioned Space)



GARAGE INSULATION DETAIL

All insulation by others. N.T.S



GARAGE INSULATION DETAIL

All insulation by others. N.T.S

Figure A.2—Sprinkler Pipe Installed in Garages (Below Conditioned Space)

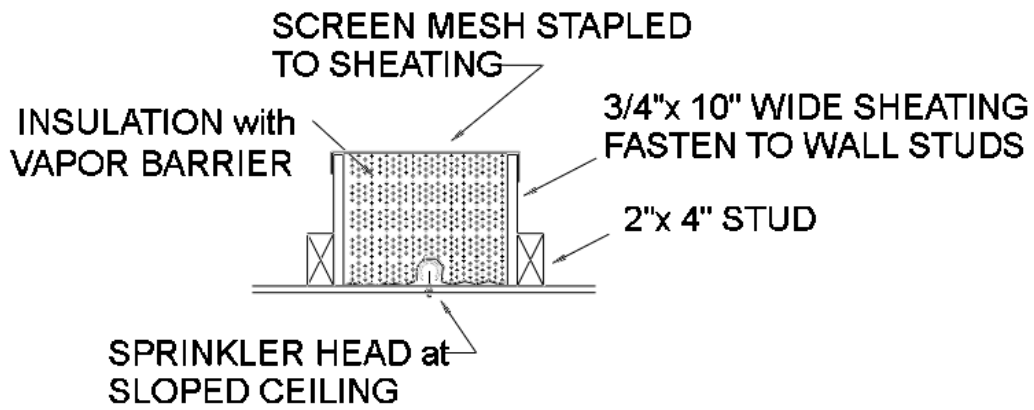

TYPICAL WALL CAVITY INSULATED BOX- PLAN VIEW

All insulation and framework by others. N.T.S

Figure A.3—Sprinkler Pipe Installed in Exterior Walls (Adjacent to Conditioned Space)

7.0 References

- [1] A. Syed, *Advanced building technologies for sustainability*, Hoboken, NJ: John Wiley & Sons, Inc, 2012.
- [2] ASHRAE, ANSI/ASHRAE/IES Standard 90.1-2019 -- Energy Standard for Buildings Except Low-Rise Residential Buildings, Atlanta, GA: ASHRAE, 2019.
- [3] W. Vliet, *The Encyclopedia of Housing*, Thousand Oaks, CA: Sage, 1998.
- [4] NFPA, NFPA 13 Standard for the Installation of Sprinkler Systems, 2019 Edition, Quincy, MA: NFPA, 2018.
- [5] NFPA, NFPA 13R Standard for the Installation of Sprinkler Systems in Low-Rise Residential Occupancies, 2019 Edition, Quincy, MA: NFPA, 2018.
- [6] NFPA, NFPA 13D Standard for the Installation of Sprinkler Systems in One- and Two-Family Dwellings and Manufactured Homes, 2019 Edition, Quincy, MA: NFPA, 2018.
- [7] K. E. Isman, "Antifreeze Alternatives - Tenting of Insulation," *Sprinkler Quarterly*, pp. 15-18, January-February 2010.
- [8] The Fire Protection Research Foundation, "Sprinkler Insulation - A Literature Review," The Fire Protection Research Foundation, Quincy, MA, 2011.